

Top view

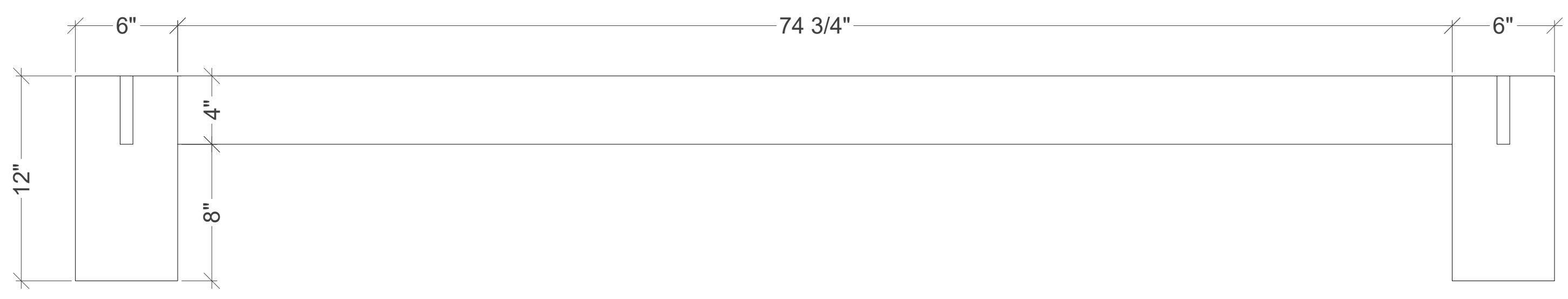

Front view

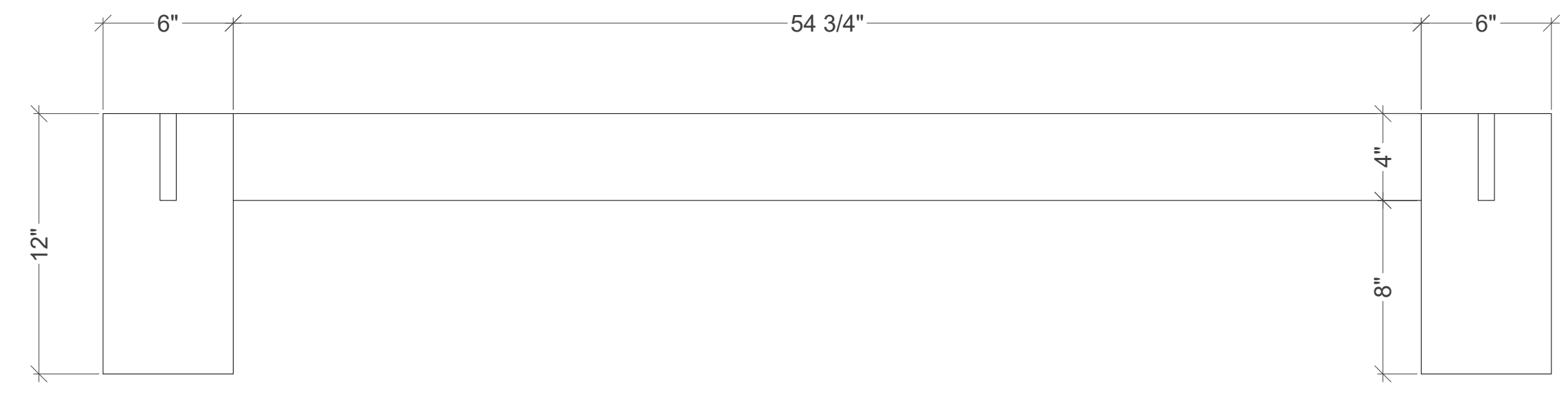

Side view

Parts list		
Name	Quantity	Dimension
bed feet	4	6"x6"x12"
right side rails	2	3/4"x4"x86 3/4"
left side rails	2	3/4"x4"x66 3/4"
Reinforcement slat	2	3/4"x1 1/2"x74 3/4"
Cross-cutting Reinforcement slat	17	3/4"x2"x 60"

### General tips

**Bed Feet:** Given their dimensions (6"x6"x12"), these are likely the supports for the corners of the bed.

For these, you might consider using traditional mortise and tenon joints, which are strong and align well with the aesthetics of Japanese design. No bolts would typically be needed if the joints are well-crafted and snug.

**Side Rails:** The side rails are long and would bear the length of the mattress. For the right and left side rails, you could again use mortise and tenon joints to connect to the bed feet.

For additional support, especially since these rails are long, consider using bed rail brackets or heavy-duty fasteners that can be tightened or replaced if needed.

**Reinforcement Slat:** These pieces appear to serve as central supports running down the middle of the bed. Depending on the bed design, they might slot into the side rails or rest on the bed feet.

A strong joint like a dovetail or a halved joint might be appropriate here, potentially reinforced with bolts or screws for extra support.

**Cross-cutting Reinforcement Slat:** With 17 pieces listed, these are probably meant to lie across the width of the bed to support the mattress.

Here, simplicity and ease of assembly or disassembly could be important, so you might opt for slat brackets that allow the slats to be easily placed and, if necessary, removed for moving the bed.

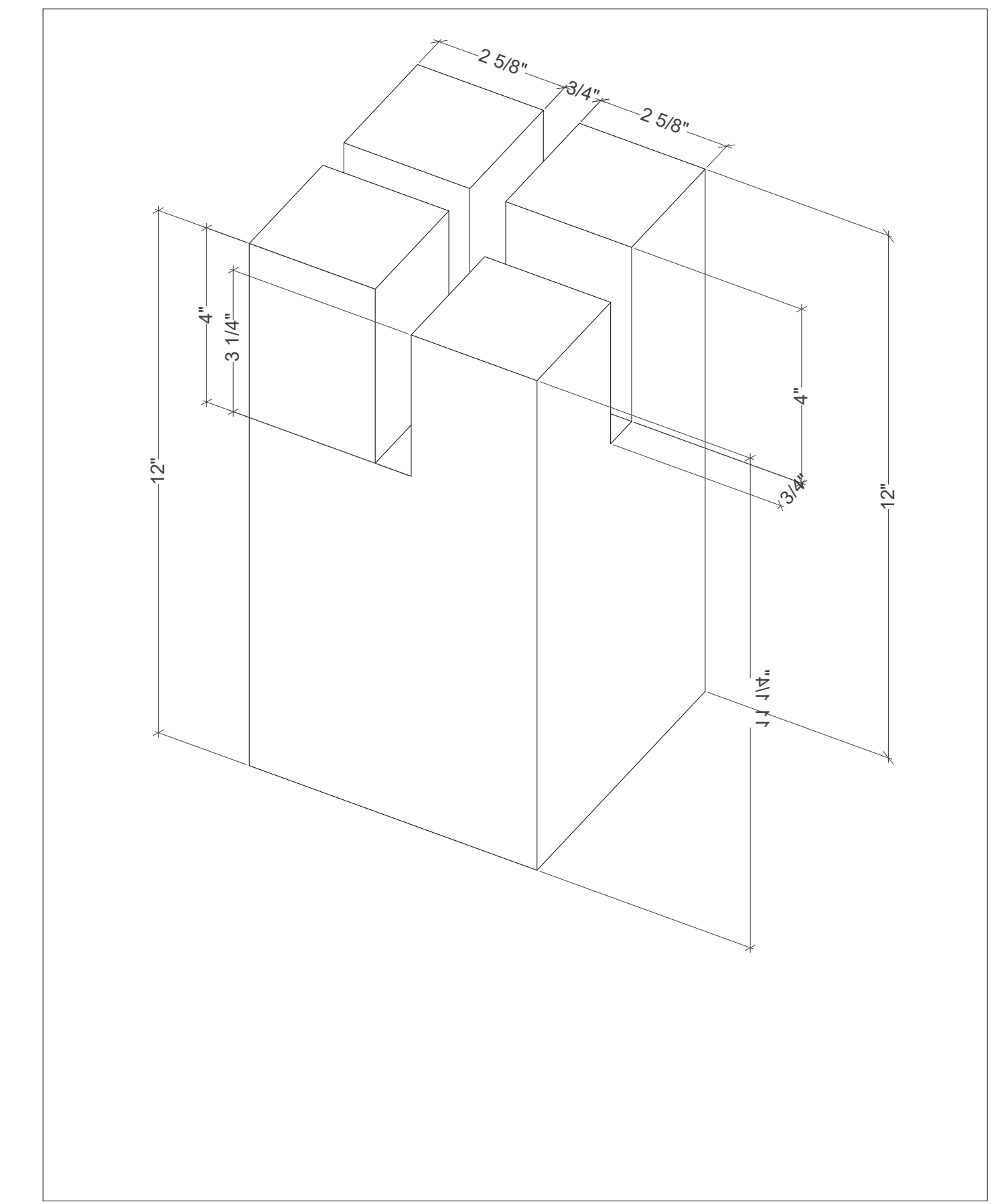
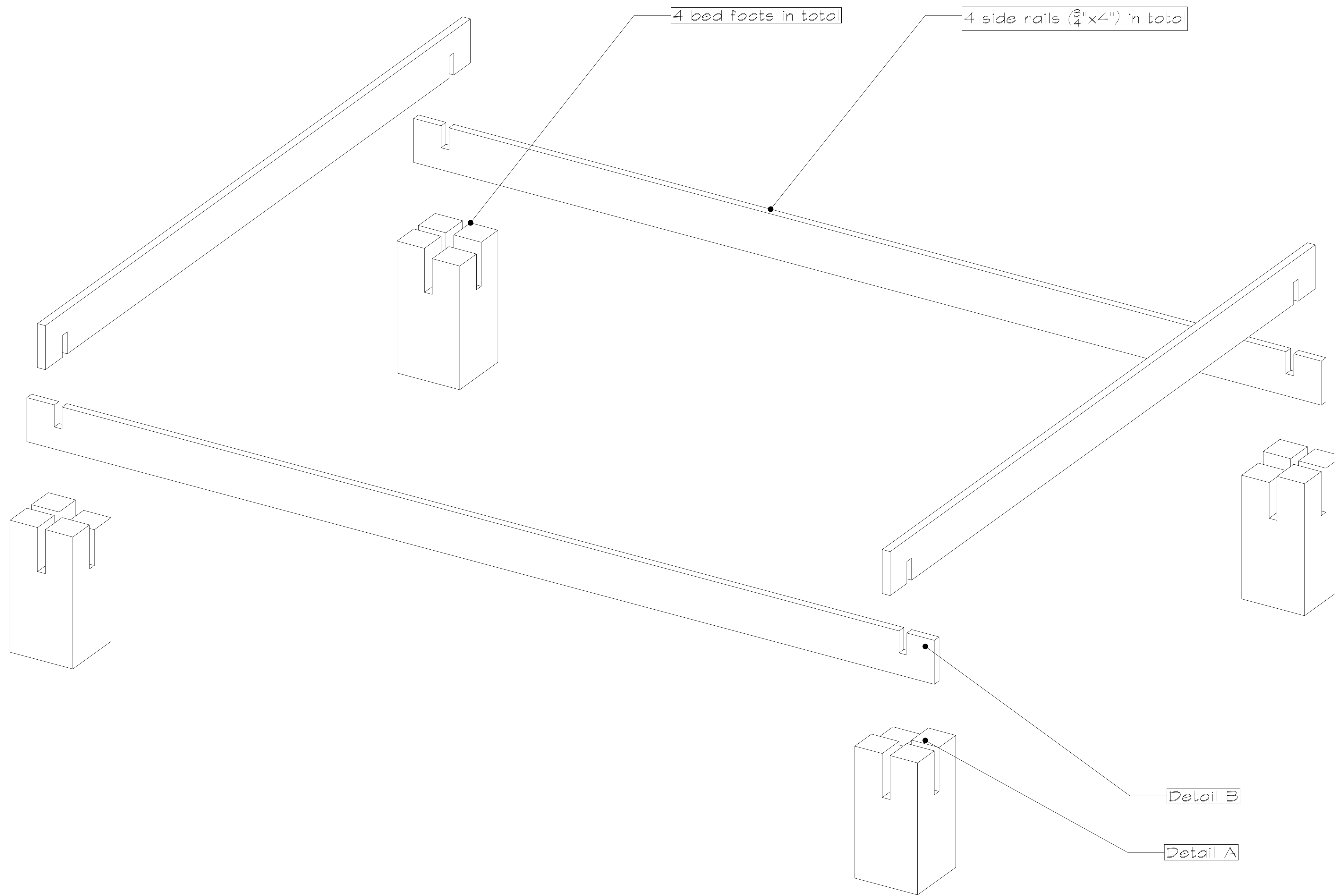

Detail A

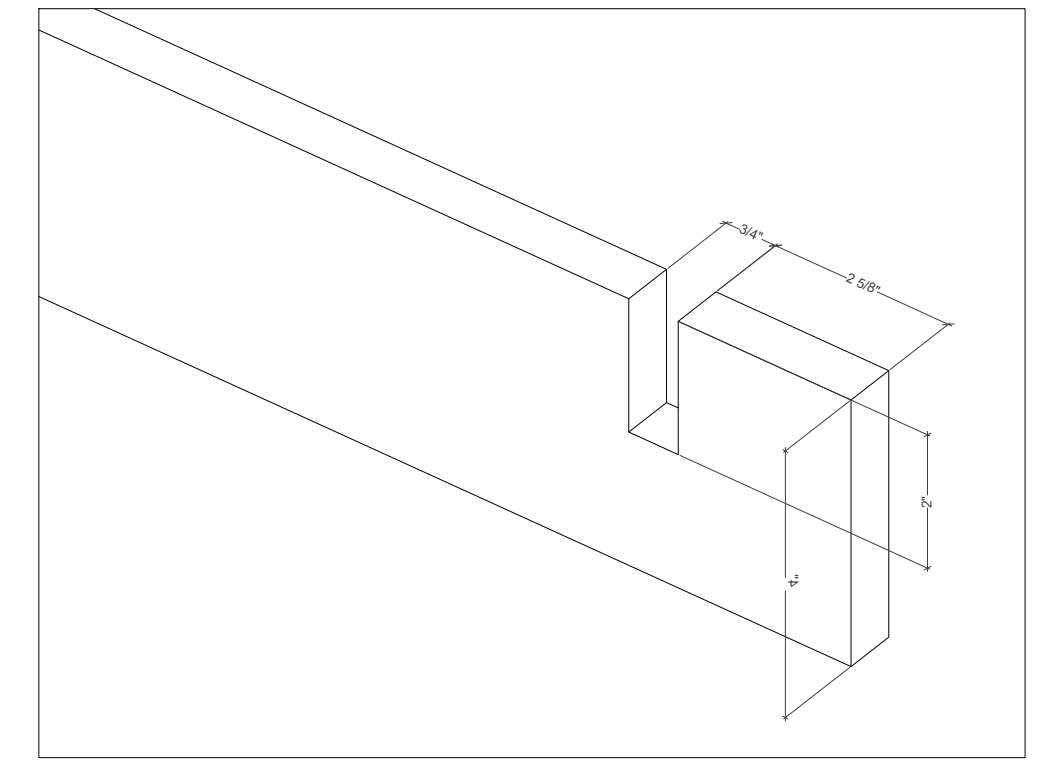

Detail B

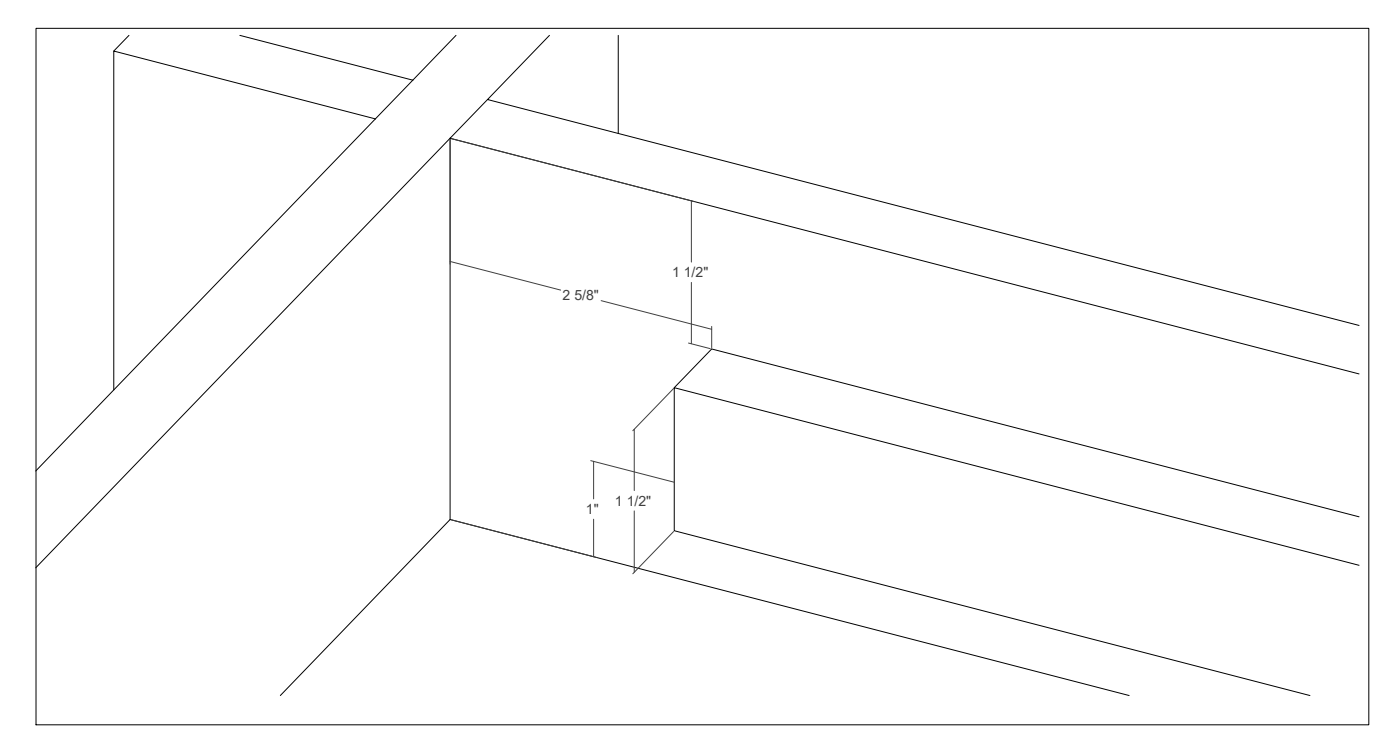
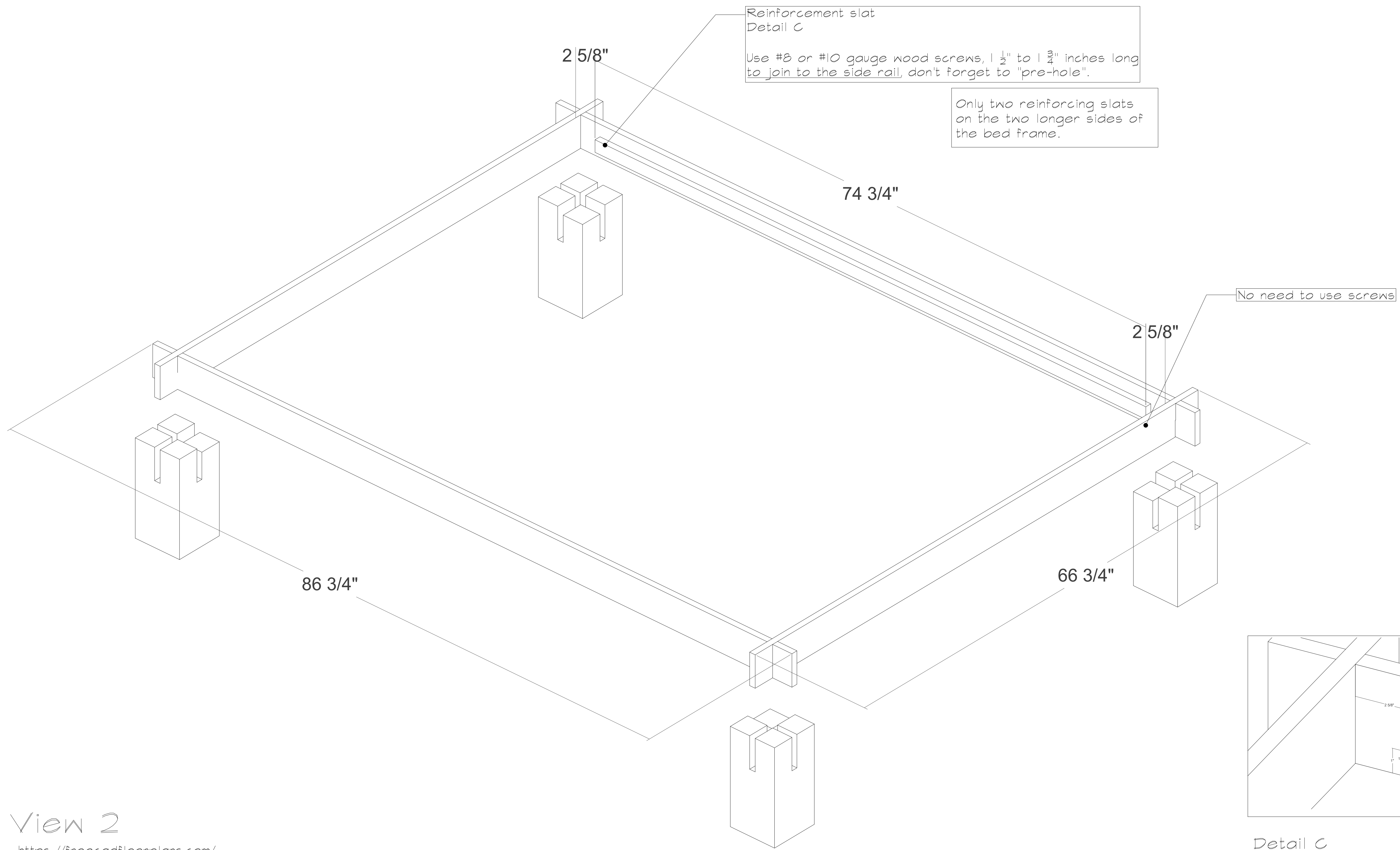

Detail C

View 2

<https://freecadfloorplans.com/>

Detail D  
Central reinforcing slat  
( $\frac{3}{4}$ "x2  $\frac{1}{2}$ ")  
Located right in the  
center of the lateral side  
rails.

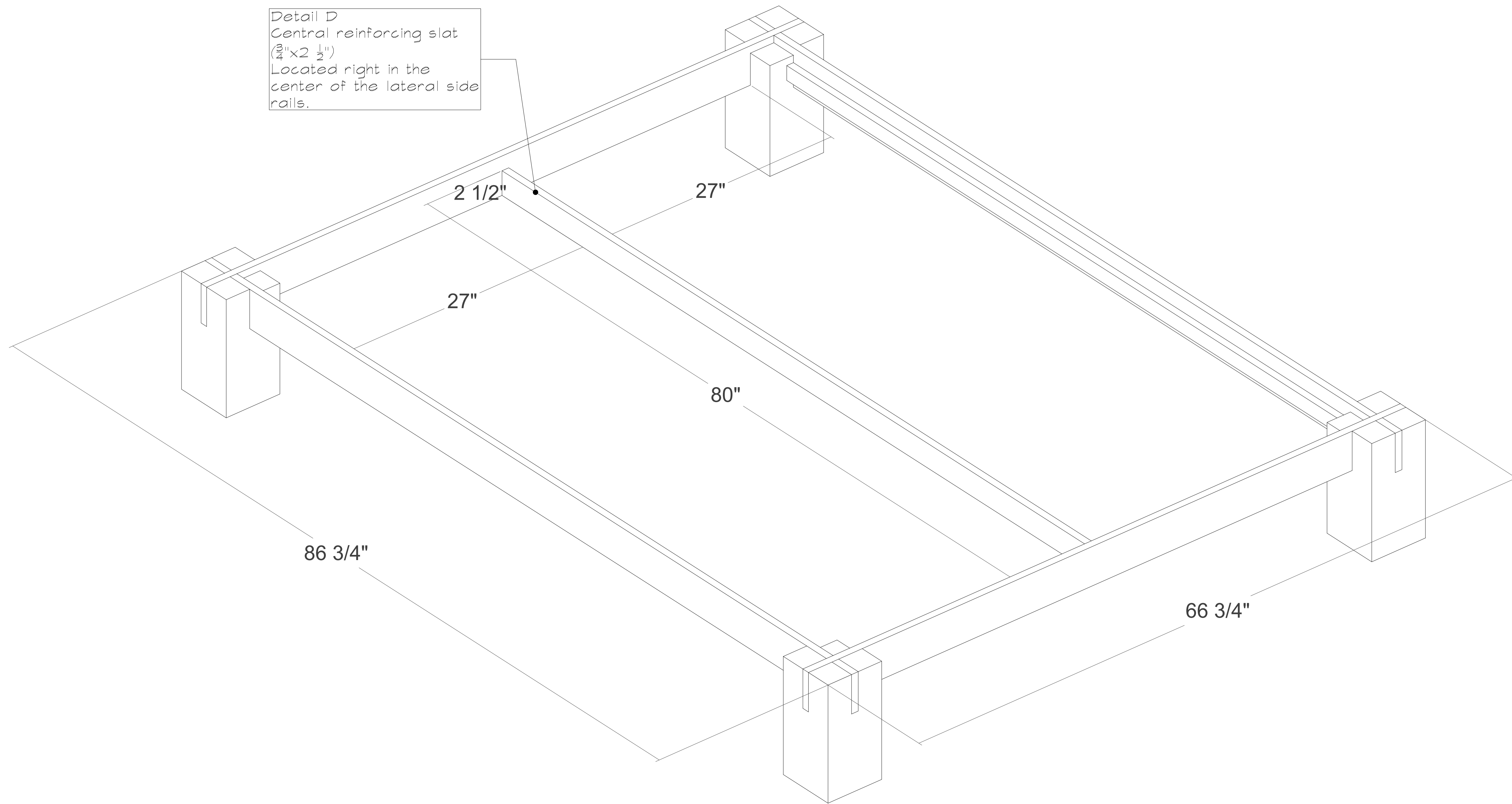

View 3

<https://freecadfloorplans.com/>

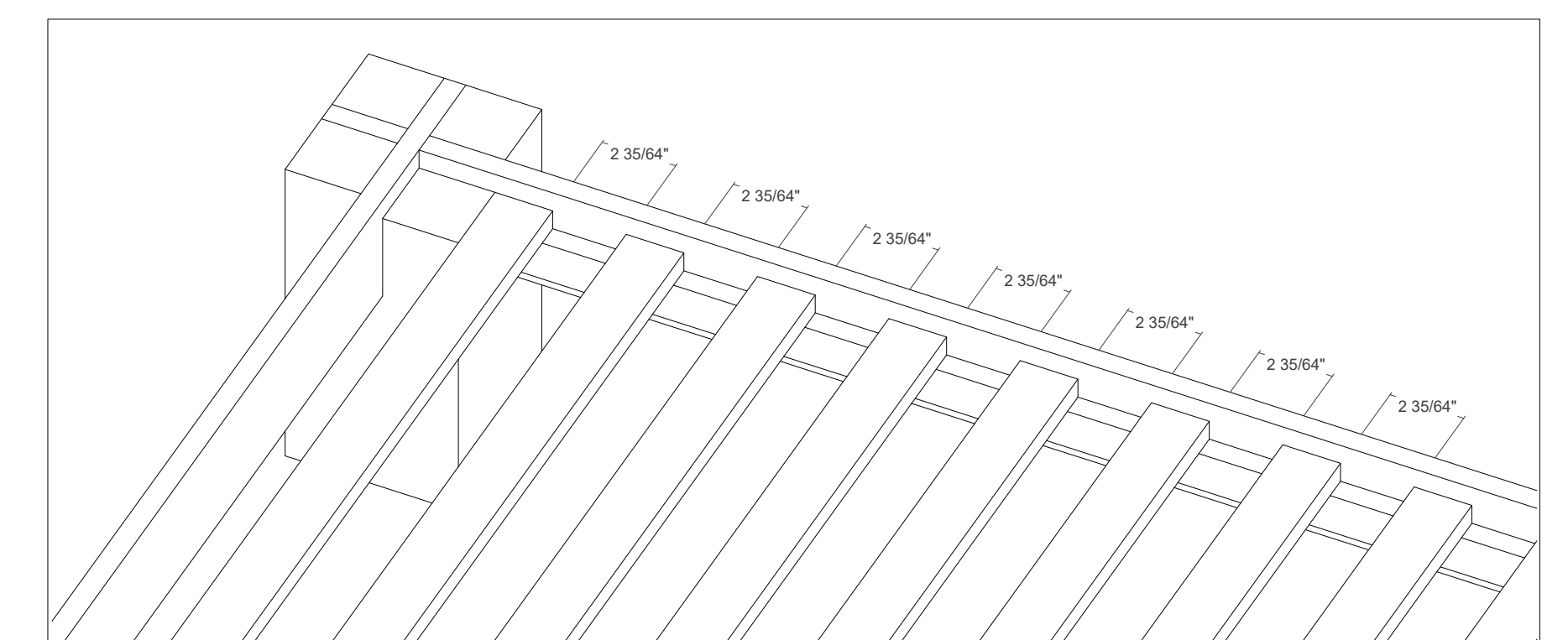
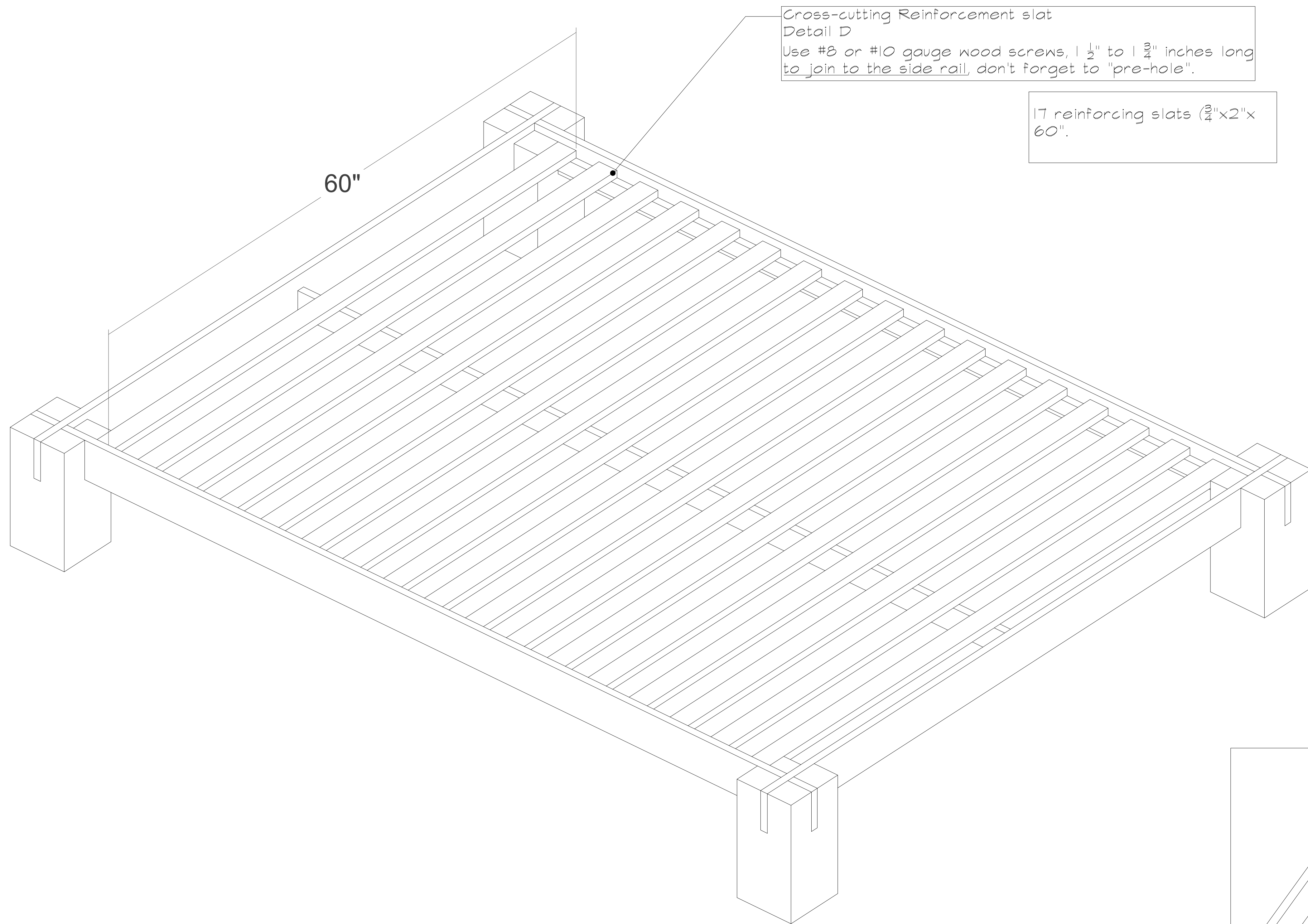

Detail D

View 4

<https://freecadfloorplans.com/>